

ACCESS SECURITY SYSTEM USING RFID TAG

OBJECTIVE

The main objective of this project is to provide the technology which can be very beneficial is that RFID automated access for door controls to buildings, departments, rooms, secured closets (wiring, PBX, etc.) and cabinets is very cost effective and secure to use. Many people do not realize how easy it is to implement card access systems such as card access door or doors using RFID readers and RFID Cards or Keyfobs for Secured Access Control Management. You can even use smart readers for computer rooms and securing individual computers.

FEATURES

- ¾ Low power requirement.
 - ¾ Excellent characters appearance.
 - ¾ Reliability.
 - ¾ Lower cost.
-
- RFID technology is based on the concept of magnetic coupling, which is the principle that current flowing in one circuit can induce current flow

in another circuit through a magnetic field generated in the space between the circuits.

PIC16F887 MICRO CONTROLLER

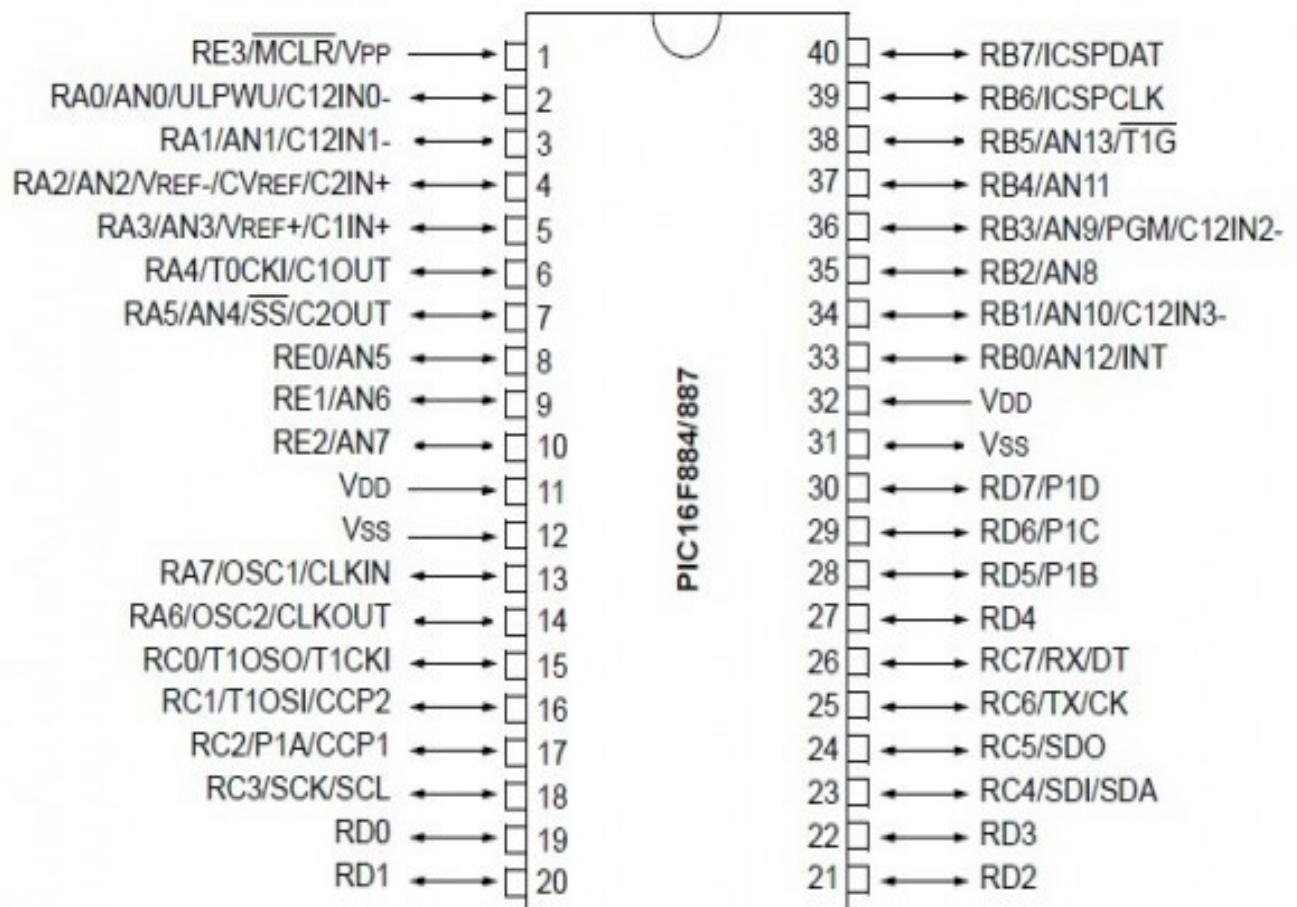

BLOCK DIAGRAM

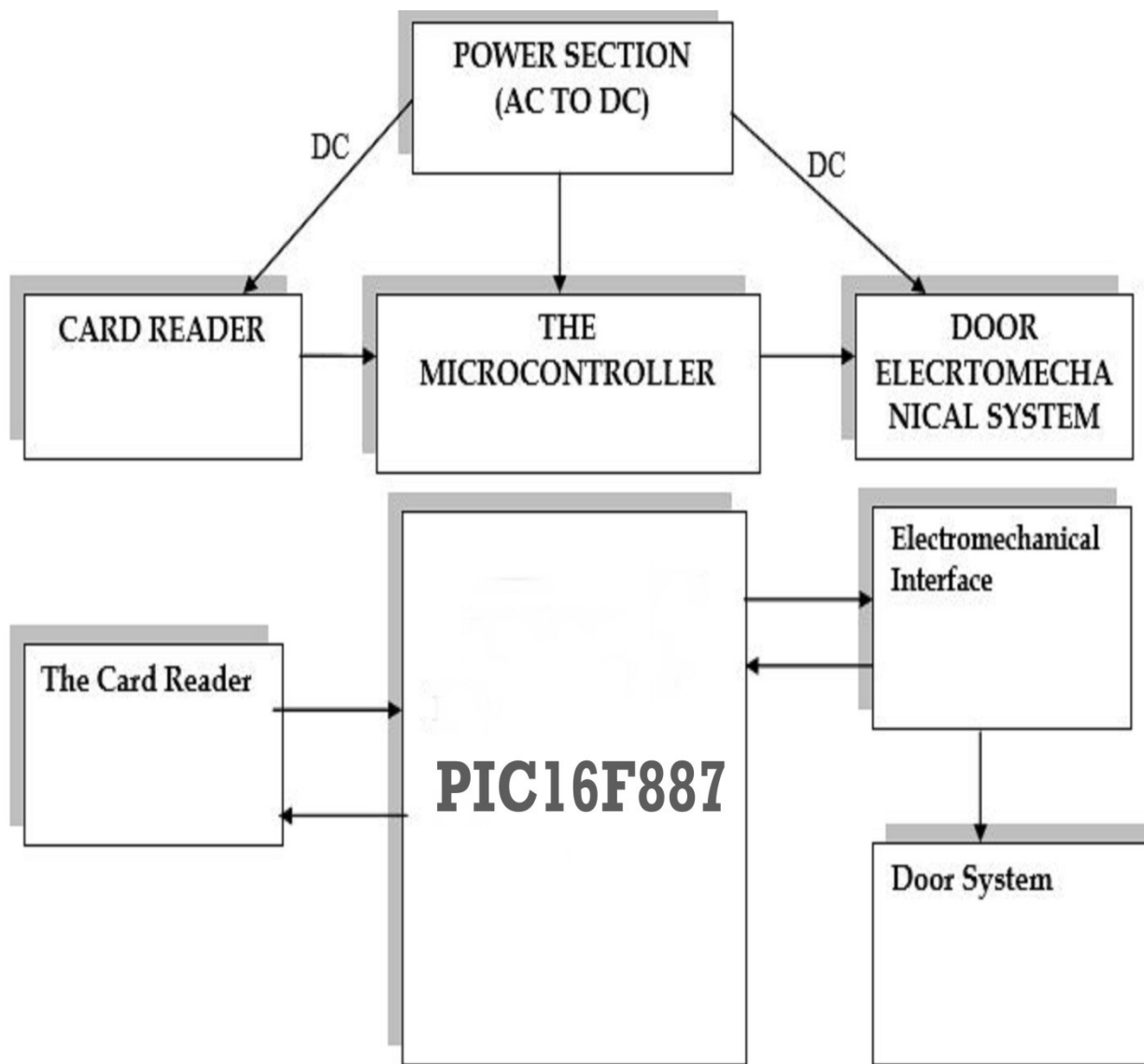
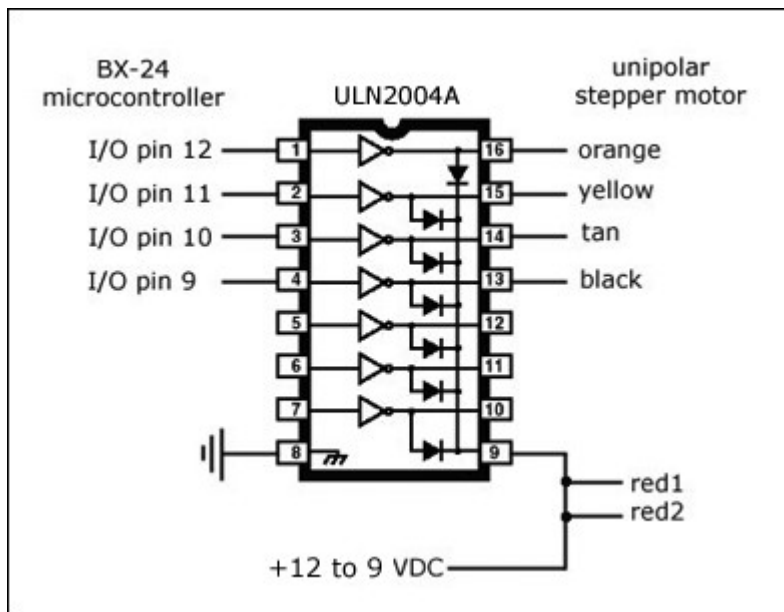

Figure 1: The Functional Block Diagram of the System.

ULN2004



Features

- Seven Darlingtons per package
- Output current 500 mA per driver (600 mA peak)
- Output voltage 50 V
- Integrated suppression diodes for inductive loads
- Outputs can be paralleled for higher current
- TTL/CMOS/PMOS/DTL compatible inputs
- Inputs pinned opposite outputs to simplify layout

RFID Reader

An **RFID reader** is a device that is used to interrogate an [RFID tag](#). The reader has an antenna that emits radio waves; the tag responds by sending back its data.

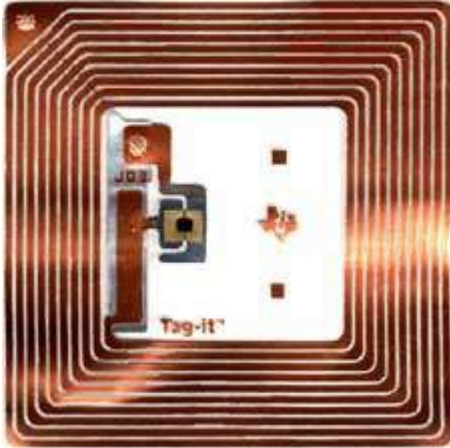

Radio-frequency identification (RFID) is a [technology](#) that uses [radio waves](#) to transfer data from an electronic tag, called RFID tag or label, attached to an object, through a reader for the purpose of identifying and tracking the object. Some RFID tags can be read from several meters away and beyond the line of sight of the reader.

The RFID tag includes a small RF transmitter and receiver. An RFID reader transmits an encoded radio signal to interrogate the tag. The tag receives the message and responds with its identification information.

A basic RFID system consists of three components:

- An antenna or coil
- A transceiver (with decoder)
- A transponder (RF tag) electronically programmed with unique information

LCD (LIQUID CRYSTAL DISPLAY)

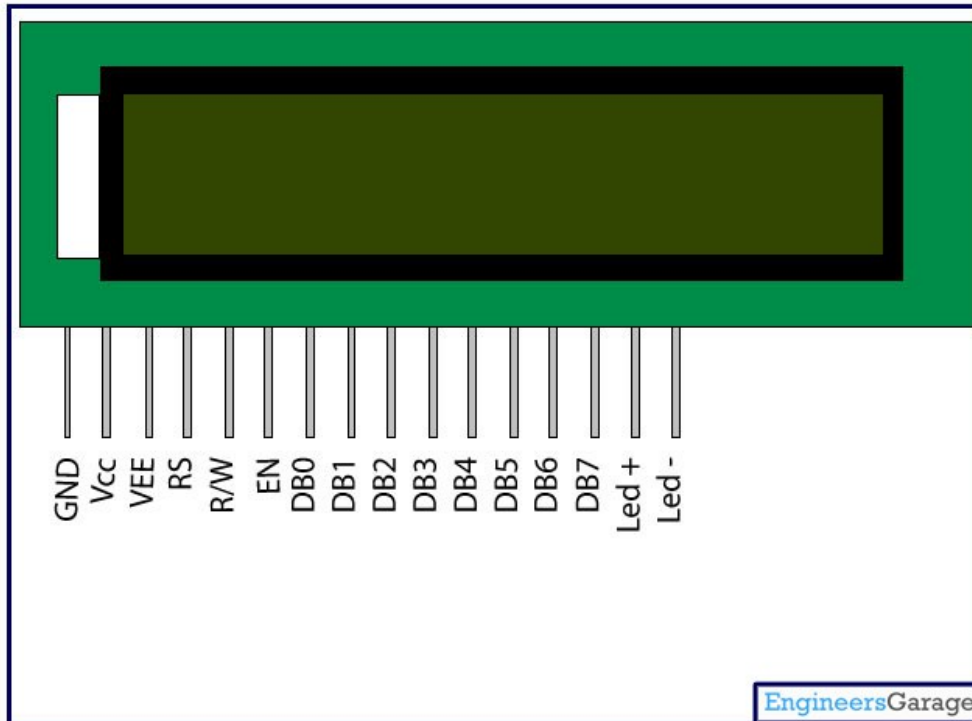

Interface pin description

Pin no.	Symbol	External connection	Function
1	V _{SS}	Power supply	Signal ground for LCM
2	V _{DD}		Power supply for logic for LCM
3	V ₀		Contrast adjust
4	RS	MPU	Register select signal
5	R/W	MPU	Read/write select signal
6	E	MPU	Operation (data read/write) enable signal
7~10	DB0~DB3	MPU	Four low order bi-directional three-state data bus lines. Used for data transfer between the MPU and the LCM. These four are not used during 4-bit operation.
11~14	DB4~DB7	MPU	Four high order bi-directional three-state data bus lines. Used for data transfer between the MPU
15	LED+	LED BKL power supply	Power supply for BKL
16	LED-		Power supply for BKL

BUZZER-

An electric signaling device, such as a doorbell, that makes a buzzing sound.

OR

1. A person or thing that buzzes
2. (Electronics) a device that produces a buzzing sound, esp one similar to an electric bell without a hammer or gong



Electromechanical Door Interface Circuit

In the model, a simple 12v DC motor and Rack and Pinion motion transmission systems were used to provide translatory motion for the door to open and close upon the command of the microcontroller unit to the relay circuitry.

The relay circuit is responsible for performing the switching action that energizes the motion transmission systems to perform door translatory motion operations. The relay circuit transforms the electrical signal from the PIC into mechanical movement that performs a switching mechanism to allow the door to open or close.

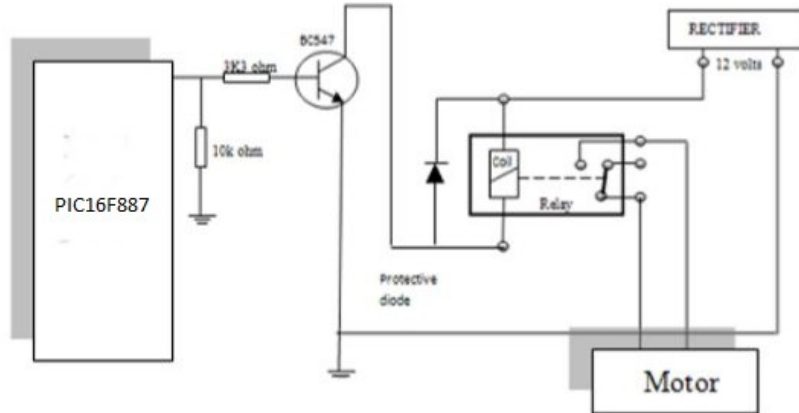

APPLICATION

- RFID based Secured access system implemented on PIC16F887 microcontroller . This is a very useful application of RFID (Radio frequency identification) and is very commonly used in institutes,offices, homes and so on.
- RFID automated access for door controls to buildings, departments, rooms, secured closets (wiring, PBX, etc.) and cabinets is very cost effective and secure to use.
- Many people do not realize how easy it is to implement card access systems such as card access door or doors using RFID readers and RFID Cards or Keyfobs for Secured Access Control Management.

ADVANTAGES

- you will not be required to carry a key. This makes it less likely that you'll lose the key and have a difficult time getting in to the home. It also means that you won't need to store a spare key somewhere on your property, as

many home owners currently do. This poses a security risk, so eliminating the need for that additional key helps to make your home safer.

DISADVANTAGES

- Systems which are powered by electricity may not function properly in the case of a power failure. This can leave your door completely locked throughout the failure, or it may result in the door not locking properly and remaining open during the failure as well. Most systems have battery backup systems

FUTURE IMPROVMENTS

- Access based entrance and exits using access smart technology is rapidly becoming the way of the future for many businesses, government buildings, hospitals, museums and other establishments requiring secured but easy to control access solutions. Access based systems use either 125 kHz RFID or 13.56 MHz RFID readers, cards and keyfobs.